

V U L K A

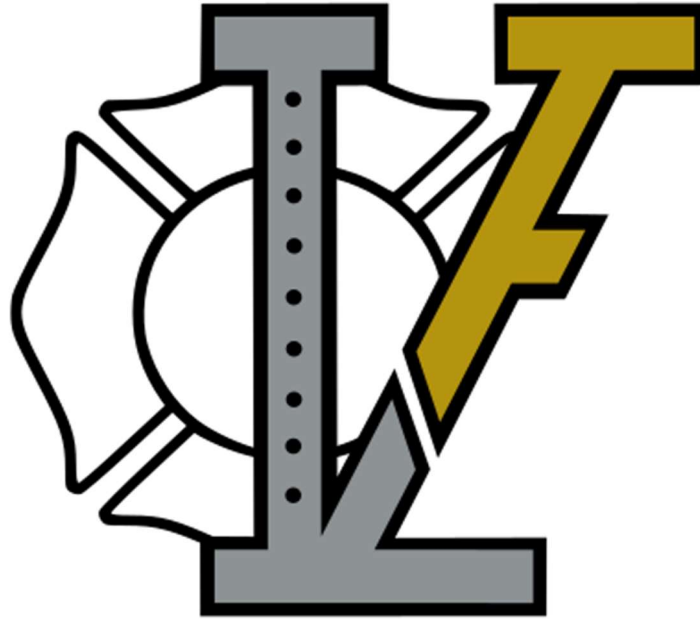

F I R E E Q U I P M E N T

VTS Field Guide:
Rebar Collar Add-On







SAFETY PRECAUTIONS



ALWAYS Use Personal Protective Equipment

Always wear appropriate P.P.E. including helmet, gloves, and eye protection when setting up and operating this equipment. Wear hearing protection during the operation of powered equipment.

Never Exceed Weight Limitations

Weight limitations for this equipment are available in this guide. Under most circumstances, this equipment can support 1500 pounds, inclusive of the weight of lumber/sheathing/materials used.

Never Use Damaged Parts

If a part is bent, cut, dented or otherwise damaged, DO NOT use that part. Replacement parts are available by contacting support@vulkafire.com. Paint/powder coat chipping and scratching are expected during normal use and will not affect the equipment operationally.

Always Use Official Vulka Parts and Hardware

Only use parts and equipment designed for this product. Using anything other than Vulka Fire Equipment approved parts will void the warranty and could lead to failure of the system and subsequent injury. Replacement parts are available by contacting support@vulkafire.com.

Do Not Practice Techniques You Have Not Been Trained On

Firefighting is a dangerous job and the techniques involved could lead to injury, even in a controlled environment, if executed poorly or improperly. Always ensure that instructors are trained and competent in the subject matter being practiced and are appropriately trained to instruct.

Do Not Operate Power Tools or Equipment You Are Not Familiar With

Always follow the manufacturer's recommended operating procedures and safety precautions when using power tools and equipment. Failure to do so could result in injury.

Always Use Fall Protection When Operating at Height

Most configurations of this system will not place the user above 4' off the ground. If using a configuration that places personnel above 4', ensure fall protection is provided per OSHA requirements.





Overview

The Vulka Training System can be utilized as a stand-alone cut tree or window bar simulator, or those capabilities can be added into other configurations. This guide will focus on the detached versions of these. These configurations are perfect for a quick training session for rookie and veteran firefighters in saw confidence, impaled objects, or window bar removal from windows of differing heights and sizes.

Tools & Materials

The following parts and materials will be needed:

- (1) VTS Unit
- ½" rebar. Quantity depends on configuration and amount of evolutions to be performed. Length will also depend on configuration, but typically 2' to 6' lengths will work well.
- Shaft collars for rebar, available on vulkafire.com. Quantity depends on desired configuration.

Set Up

This Field Guide will cover how to set this configuration up properly:

- Set up tube and brackets for standalone cut tree and window bars
- Insert and secure rebar

See below for more detailed steps and diagrams.

Set Up Time

Set up time should take approximately 10 minutes.

Inserting and Securing Bolts

When securing bolts with wing nuts, bolts should only be hand tight. Using a 3/8" hex key will help snug the bolts tight and reduce play in the system. **Do not overtighten the bolts or use any powered tools on the bolts.** Overtightening the bolts could lead to permanent bending of the brackets and difficulty removing the bolts. Though uncommon, a bolt may require light tapping with a rubber mallet when inserting or removing due to slight hole size variance and/or powder coating thickness – if this is needed, be sure to use as little force as necessary to get the bolt through.

It is recommended to use the 3/8" hex key to tighten bolts until brackets are firmly in place with little play.

Assembly – Low Window Bars/Impalement Fence

1. Assembling the Structure

- a. Assemble (2) base rails in the following configuration:

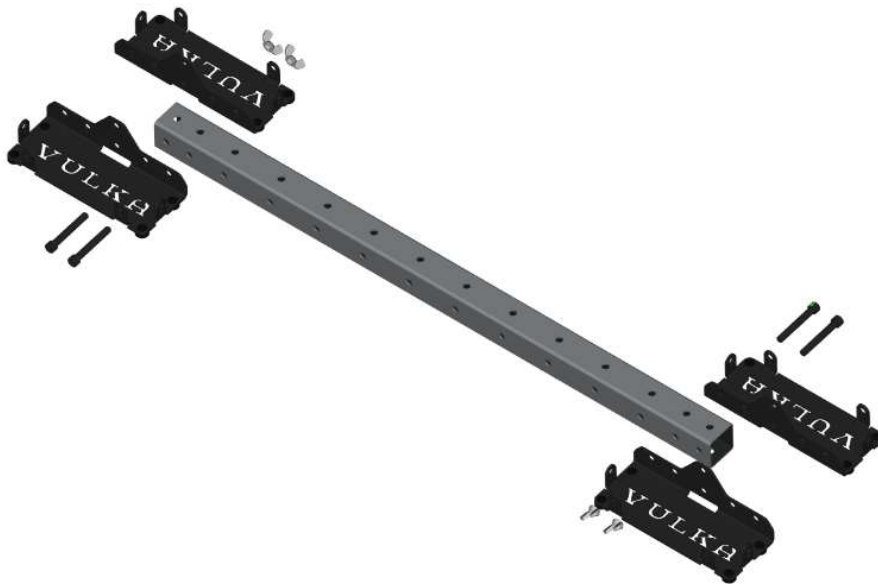

- b. Assemble the uprights on each base rail using a tube and elbow. Ensure that both uprights are placed opposite of each other. Place elbows on each upright. The distance between the elbows will determine the overall window height.

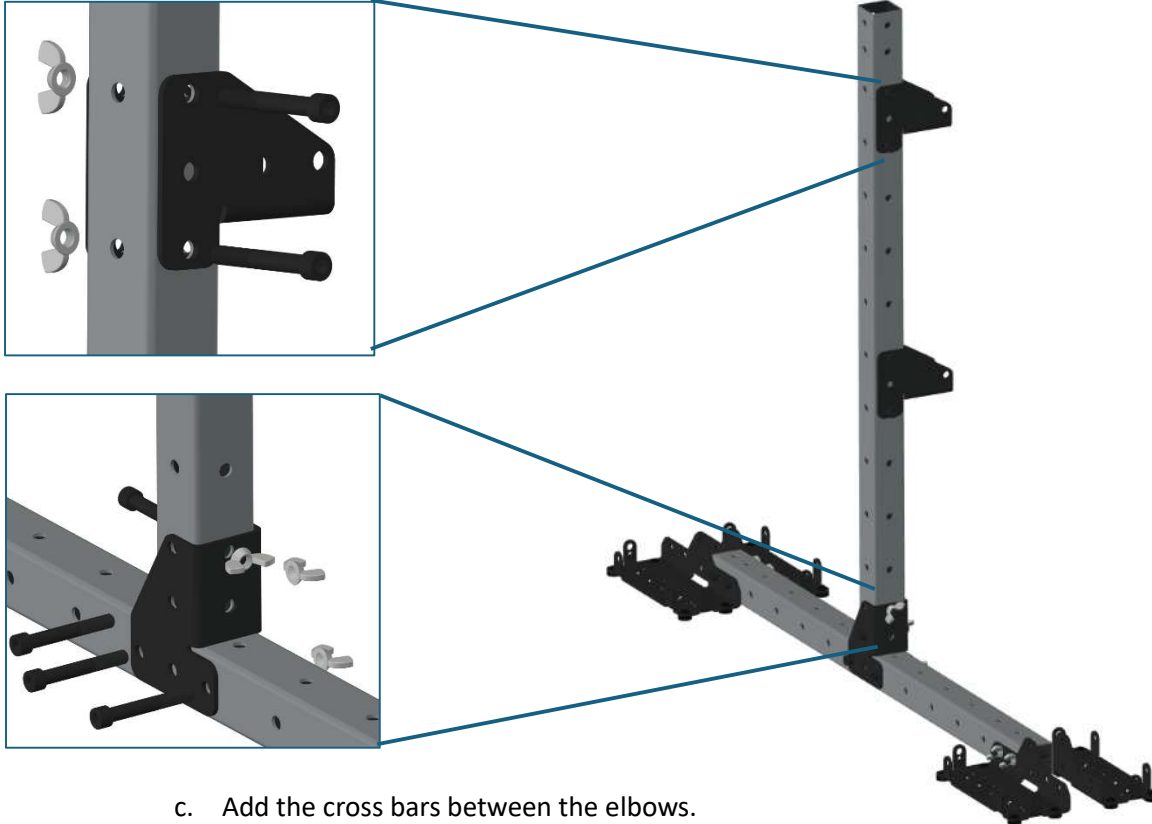

- c. Add the cross bars between the elbows.

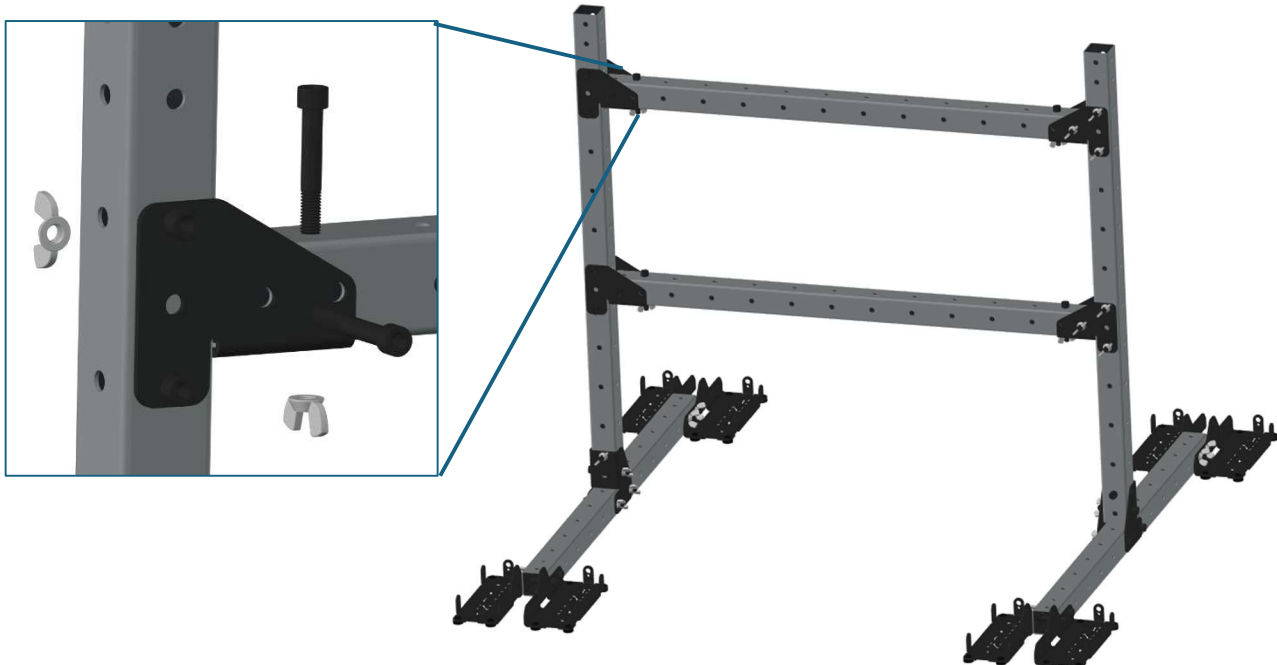

2. Adding Rebar

Start by deciding where the rebar is to be placed. Rebar can be placed through any of the holes in the tube (not being used for other parts). Place a bolt and wing nut through the holes where the bottom of the rebar will rest.

The rebar will be threaded through each tube segment and rest on the bolt at the bottom. As the rebar is threaded through each section of tube from the top, place a collar around it that will rest on the top of each tube. A collar is not needed on the bottom most tube. Tighten the set screw in the collar (this prevents the rebar from falling straight through once cut).

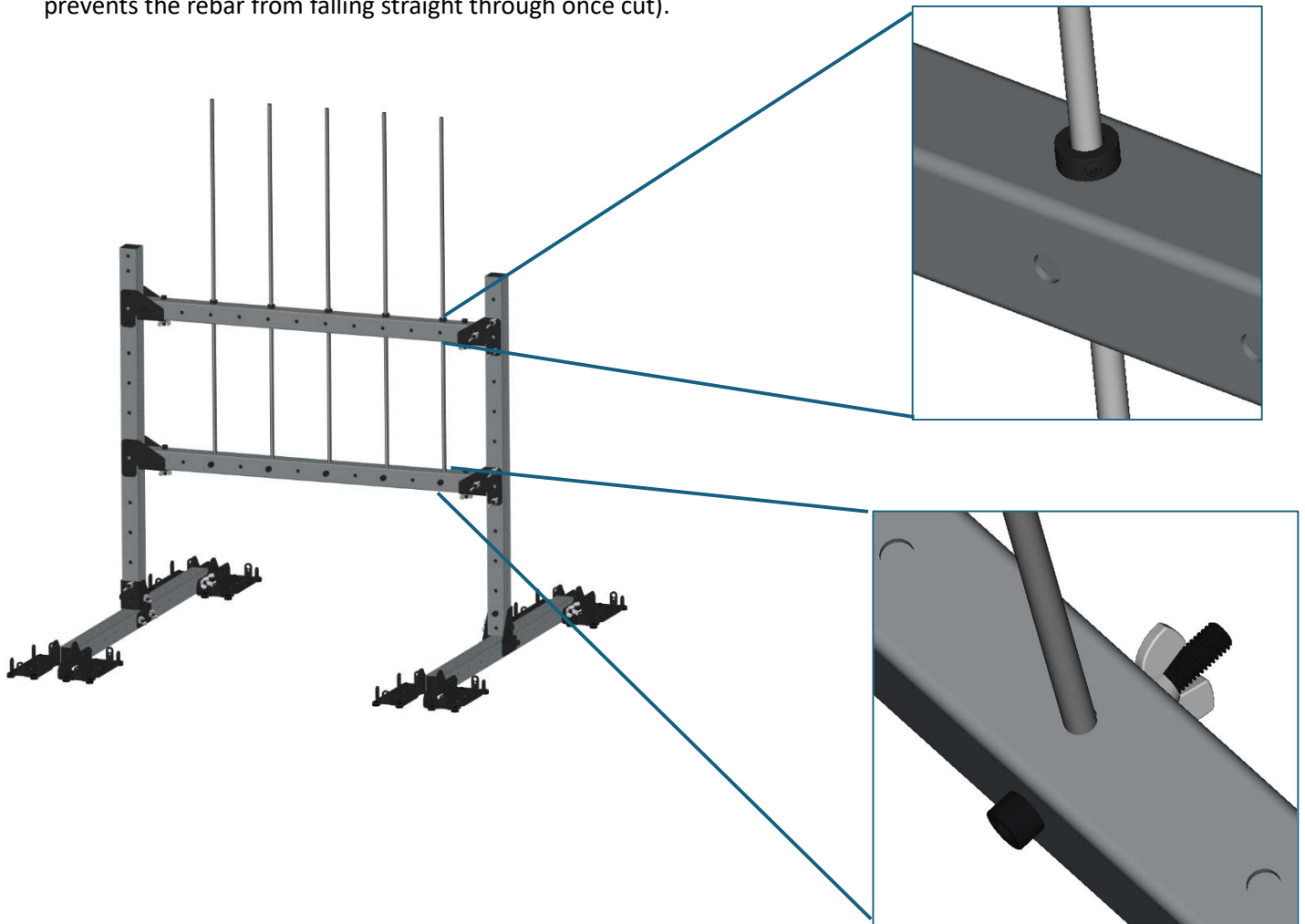

3. Final Assembly & Check

Before use, be sure to verify that all bolts are in place and hand tight, and all collar set screws are tightened.

At this point, the VTS is ready for use. Review safety precautions before training begins.

Assembly – High Window

1. Assembling the Structure

- a. Repeat steps 1(a) and 1(b) for the low window configuration, except do not add horizontal elbows.
- b. Add connectors and another tube to both uprights, resulting in **(2)** double height tube structures as shown:

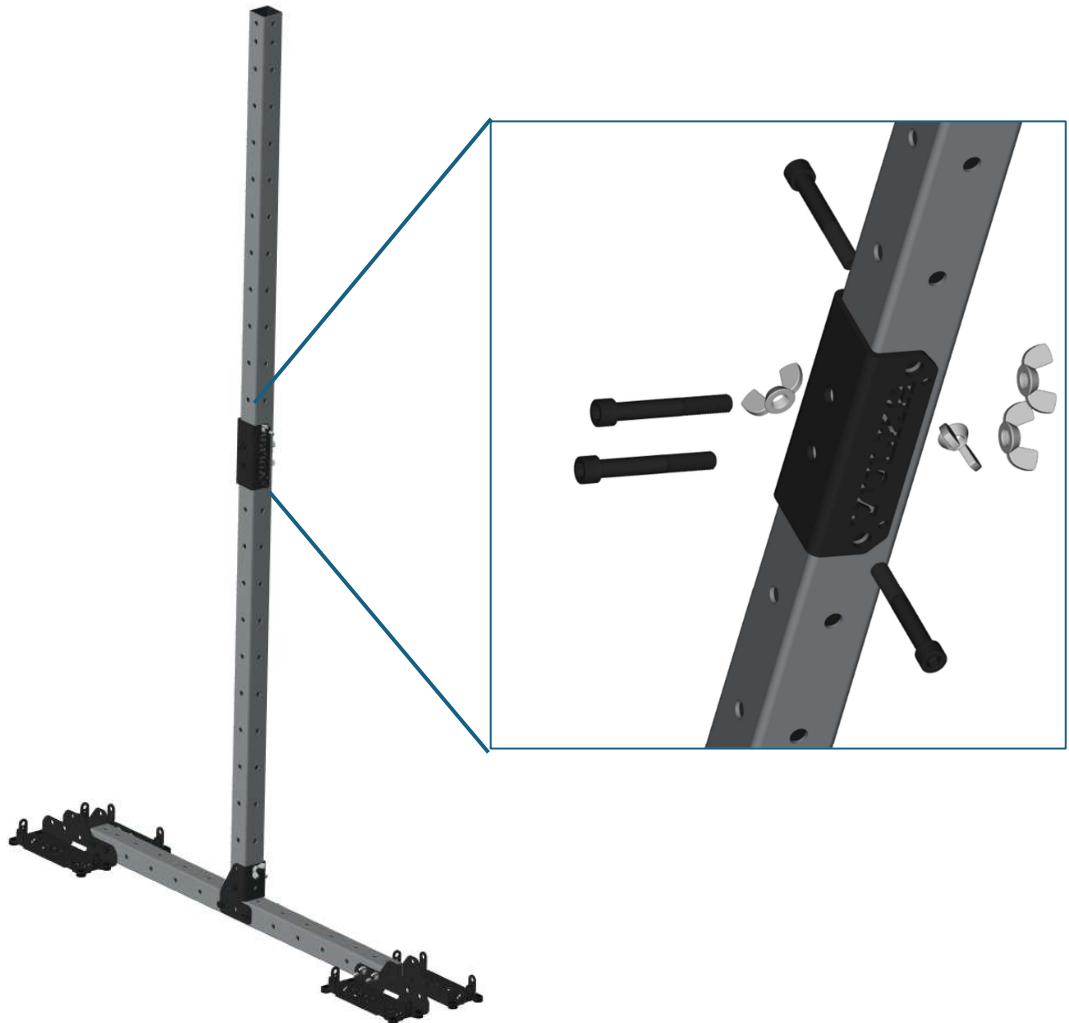

- c. Add elbows and cross bars as shown in steps 1(b) and 1(c) for the low window configuration. The distance between the elbows will determine the overall window height.



2. Adding Rebar

Add rebar as shown in step 2 for the low window configuration:



3. Final Assembly & Check

Before use, be sure to verify that all bolts are in place and hand tight, and all collar set screws are tightened.

At this point, the VTS is ready for use. Review safety precautions before training begins.

Assembly – Cut Tree

1. Assembling the Structure

- a. Assemble an upright tube structure as shown below:

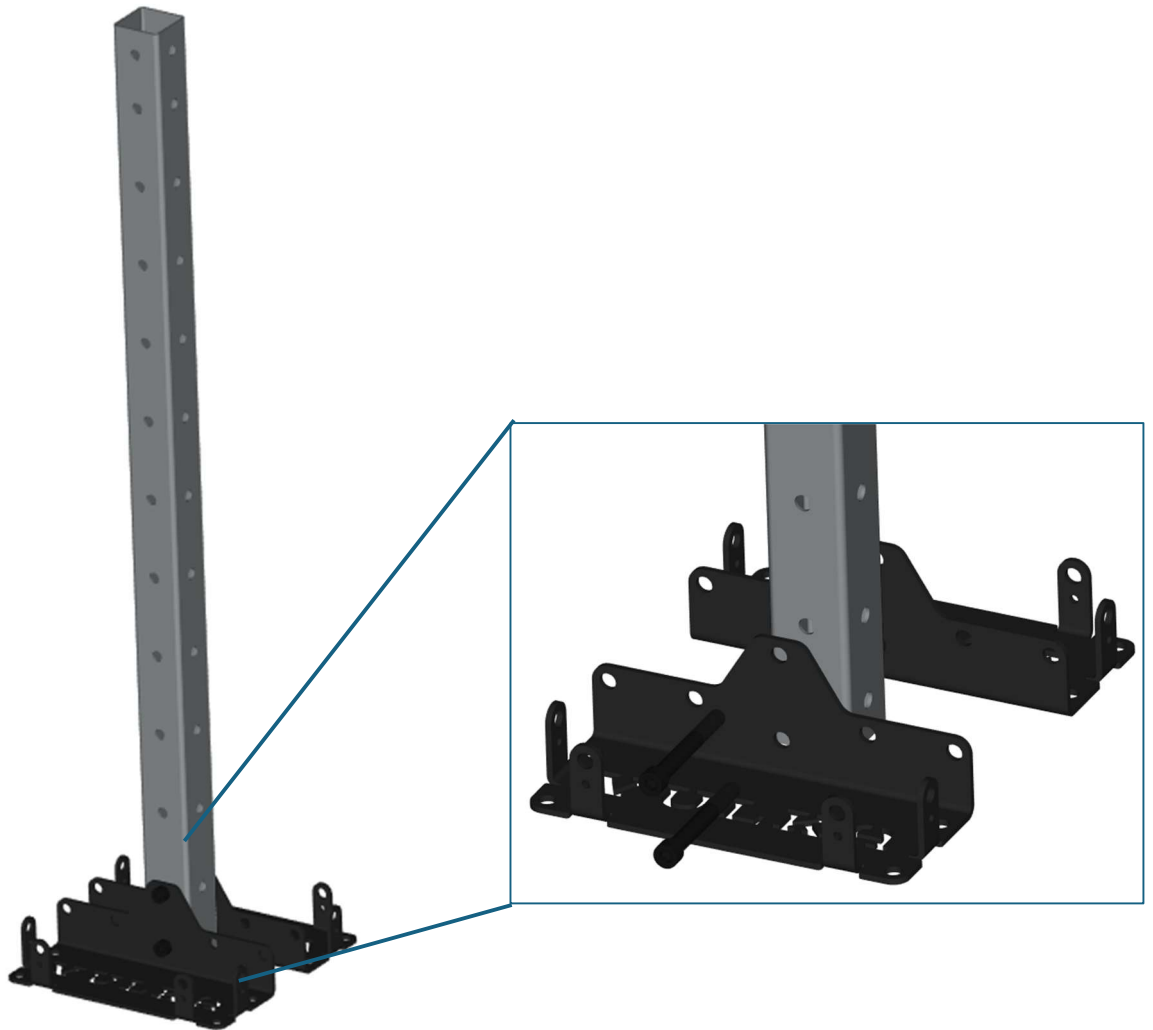

2. Adding Rebar

Start by deciding where the rebar is to be placed. Rebar can be placed through any of the holes in the tube (not being used for other parts).

The rebar will be threaded through the tube and be secured on both sides with a rebar collar. The collar should be as close to the tube as possible on both sides to limit rebar movement. Tighten the set screw in the collar (this prevents the rebar from falling straight through once cut).

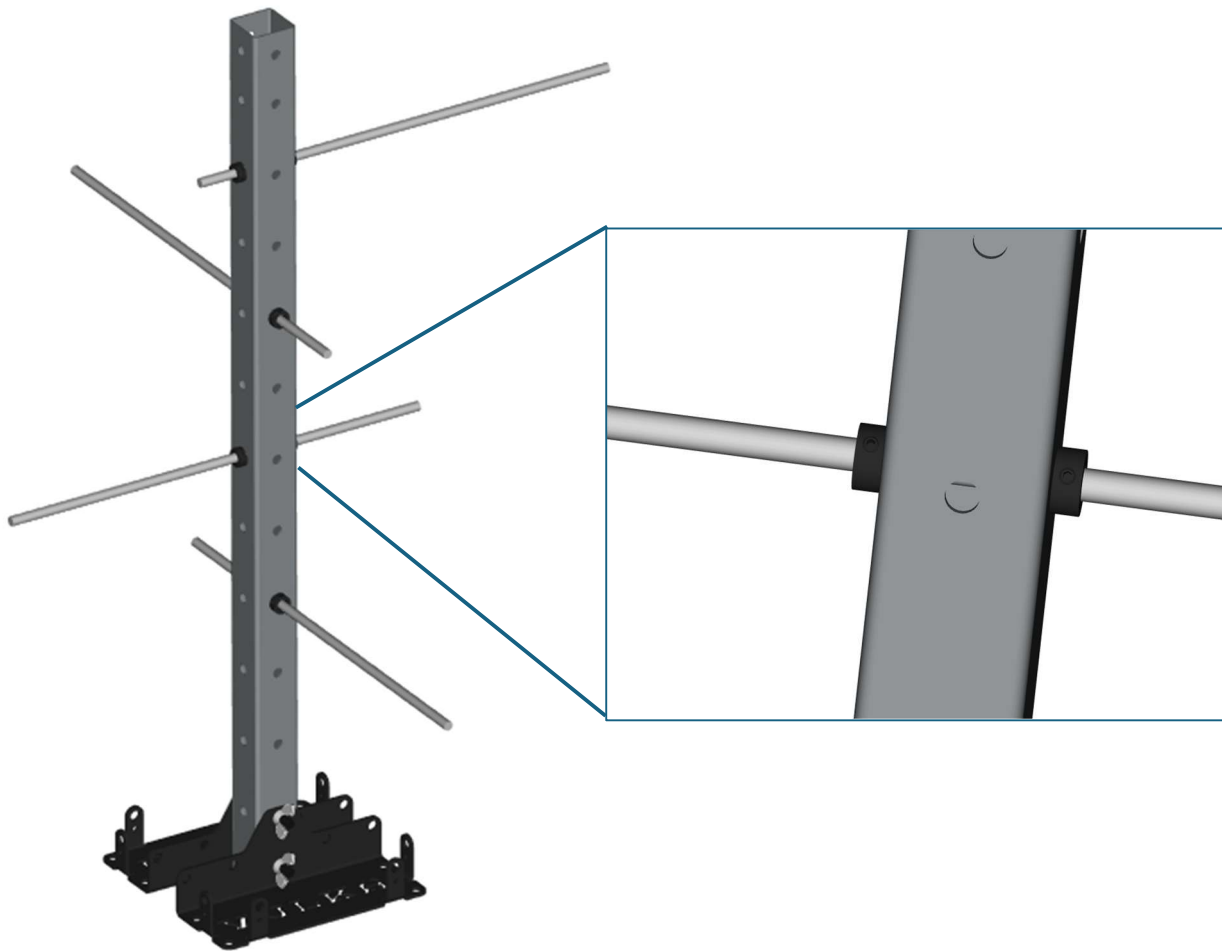

3. Final Assembly & Check

Before use, be sure to verify that all bolts are in place and hand tight, and all collar set screws are tightened.

At this point, the VTS is ready for use. Review safety precautions before training begins.



Question? Concerns? Improvements?

Please be sure to reach out to us at support@vulkafire.com !

General information and additional configurations are available in their own Field Guide. Please be sure to check vulkafire.com.

Add-ons for the VTS are also available at vulkafire.com!