

# VULKA FIRE EQUIPMENT

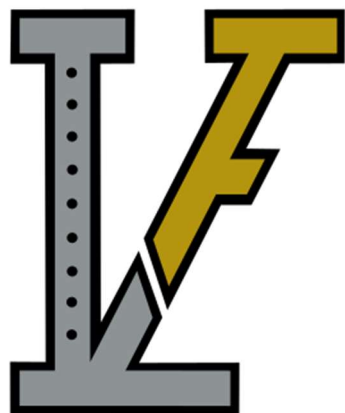

VTS Field Guide:

General Information and Care



## **SAFETY PRECAUTIONS**



### **ALWAYS Use Personal Protective Equipment**

Always wear appropriate P.P.E. including helmet, gloves, and eye protection when setting up and operating this equipment. Wear hearing protection during the operation of powered equipment.

### **Never Exceed Weight Limitations**

Weight limitations for this equipment are available in this guide. Under most circumstances, this equipment can support 1500 pounds, inclusive of the weight of lumber/sheathing/materials used.

### **Never Use Damaged Parts**

If a part is bent, cut, dented or otherwise damaged, DO NOT use that part. Replacement parts are available by contacting [support@vulkafire.com](mailto:support@vulkafire.com). Paint/powder coat chipping and scratching are expected during normal use and will not affect the equipment operationally.

### **Always Use Official Vulka Parts and Hardware**

Only use parts and equipment designed for this product. Using anything other than Vulka Fire Equipment approved parts will void the warranty and could lead to failure of the system and subsequent injury. Replacement parts are available by contacting [support@vulkafire.com](mailto:support@vulkafire.com).

### **Do Not Practice Techniques You Have Not Been Trained On**

Firefighting is a dangerous job and the techniques involved could lead to injury, even in a controlled environment, if executed poorly or improperly. Always ensure that instructors are trained and competent in the subject matter being practiced and are appropriately trained to instruct.

### **Do Not Operate Power Tools or Equipment You Are Not Familiar With**

Always follow the manufacturer's recommended operating procedures and safety precautions when using power tools and equipment. Failure to do so could result in injury.

### **Always Use Fall Protection When Operating at Height**

Most configurations of this system will not place the user above 4' off the ground. If using a configuration that places personnel above 4', ensure fall protection is provided per OSHA requirements.



## Overview

The Vulka Training System (VTS) is a modular and adaptable fire service training solution. It has many different and customizable configurations to create a broad range of training scenarios and options. This field guide is intended to cover general information regarding the system. Use this field guide in conjunction with the field guides available for specific configurations.

## Care & Maintenance

Check the VTS before and after use for damage. Look for deep gouges, cracking, warping, or bending. If any significant damage is found, place the part out of service. Replacement parts are available by emailing [support@vulkafire.com](mailto:support@vulkafire.com).

If a part does not function correctly and has not been damaged, it may be covered by the 2 year warranty. Please contact [support@vulkafire.com](mailto:support@vulkafire.com) for more information.

Scratches, abrasions, and powder coat chips are to be expected over the course of normal use. Parts can be touched up with any metal-safe paint to prevent rust from forming. Be sure to plug the holes and avoid overspray when applying paint so the bolts still fit correctly.

Ensure that if parts come into contact with fuel or other liquids that they are cleaned and dried. Water is fine on the parts, but they should be fully dry when stored. Like anything constructed from steel, the parts are subject to rust.

## Storage

The VTS parts and add-ons should be stored indoors, in a climate controlled and dry environment to ensure their longevity. We encourage the use of the VTS both indoors and outdoors, but the system should not be left or stored outdoors for extended periods of time or rusting may occur. The two year warranty does not cover rust damage.

The VTS can be stored partially broken down. For example, the lumber can be removed from the flat roof configuration and the 2 tube structures stored together so it is quickly ready next time.



## Weight Limits

Due to the varying configurations of the VTS, the weight limit can change. In any configuration, a weight limit of 1500 pounds should not be exceeded, which should take into consideration the weight of the lumber used. If the weight limit is under 1500 pounds, the field guide specific to that configuration will note the actual capacity.

Regardless of the weight capacity of the steel structure, the configuration of the lumber could limit the ultimate capacity of the system. The capacity of the lumber depends on several factors, including the type of wood, the nominal size of the wood, the length of the wood, and spacing of the wood. The following charts show the maximum allowable span based on nominal size and spacing:

| Maximum Allowable Lumber Span for VTS |              |     |     |     |
|---------------------------------------|--------------|-----|-----|-----|
|                                       | O.C. Spacing |     |     |     |
| Nom. Size                             | 12"          | 16" | 20" | 24" |
| <b>2x6</b>                            | 12'          | 10' | 9'  | 8'  |
| <b>2x8</b>                            | 15'          | 13' | 12' | 10' |
| <b>2x10</b>                           | 18'          | 15' | 14' | 12' |

Note: 2x4 lumber should only be used for framing out non-bearing sections of the system, such as vertical walls or windows

This chart is for lumber spans only, based on #2 Southern Pine (commonly available from big box retailers). The maximum width of the metal VTS structure should not exceed 3 tube lengths (12').

For other spacings or other species of lumber, the American Wood Council has an excellent calculator available on their website (<https://awc.org/calculators/span-options-calculator-for-wood-joists-and-rafters/>).

If at any point during usage the structure or lumber begin to show signs of failure (cracking, bending, warping, twisting) **immediately stop usage** and evaluate. When using multiple tube sections together, there may appear to be a slight sag towards the middle. This is normal and is caused by the small amount of extra space in the parts that allows them to fit together easily. This sag is different that seeing a physical bend in an individual piece of tube or part.

## VTS Parts Guide

Below are the parts that come standard with a VTS unit:

### Tube:

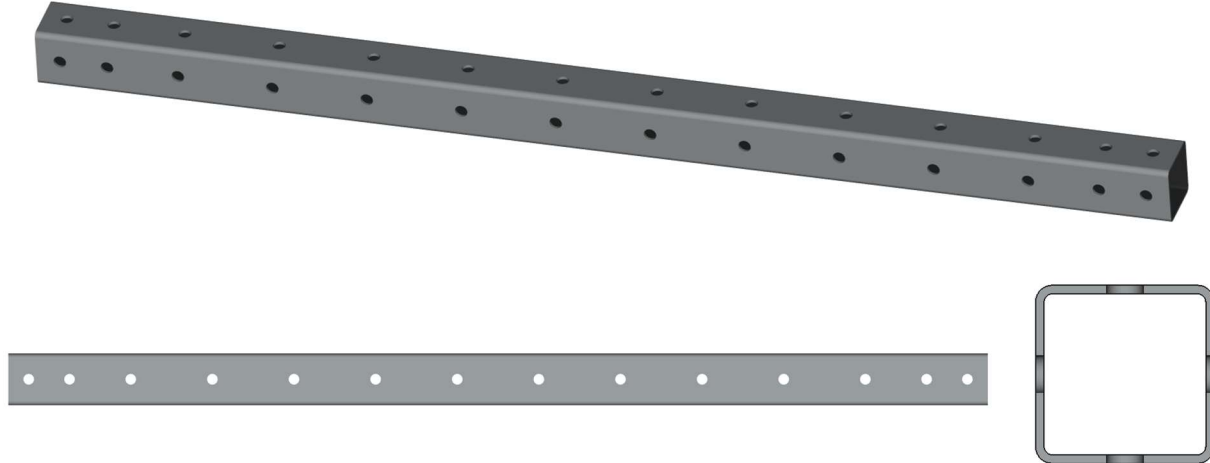

The workhorse of the VTS. The tube forms most of the structure and carries the weight of the system. The tube is made from powder coated 2.5"x2.5" structural square tube. Holes are slightly larger than 1/2" and are located on all 4 sides of the tube. They are space 4" apart on center (with the exception of the first hole on each side, which is used for connection to the other parts). Due to the nature and physics behind powder coating, the inside of the tube is unable to be powder coated, so care must be taken to not store these parts in a damp environment.

**Base:**

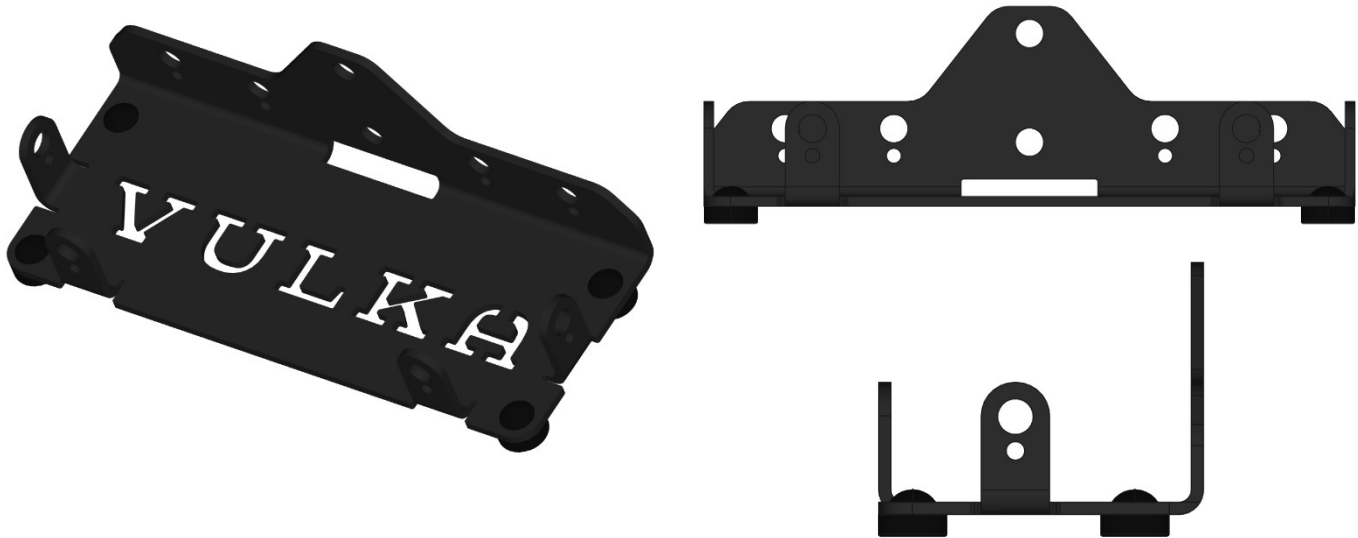

The bases attach to the tube to form a platform to stabilize the system. The bases come with rubber feet that protect the part and the floor from damage and help to prevent slipping. The feet are easily replaceable should they become damaged.

When securing a tube in a vertical or horizontal position, a base is usually needed on both sides of the tube to form a rectangular structure (certain configurations contain a single base set up, covered in those specific Field Guides):

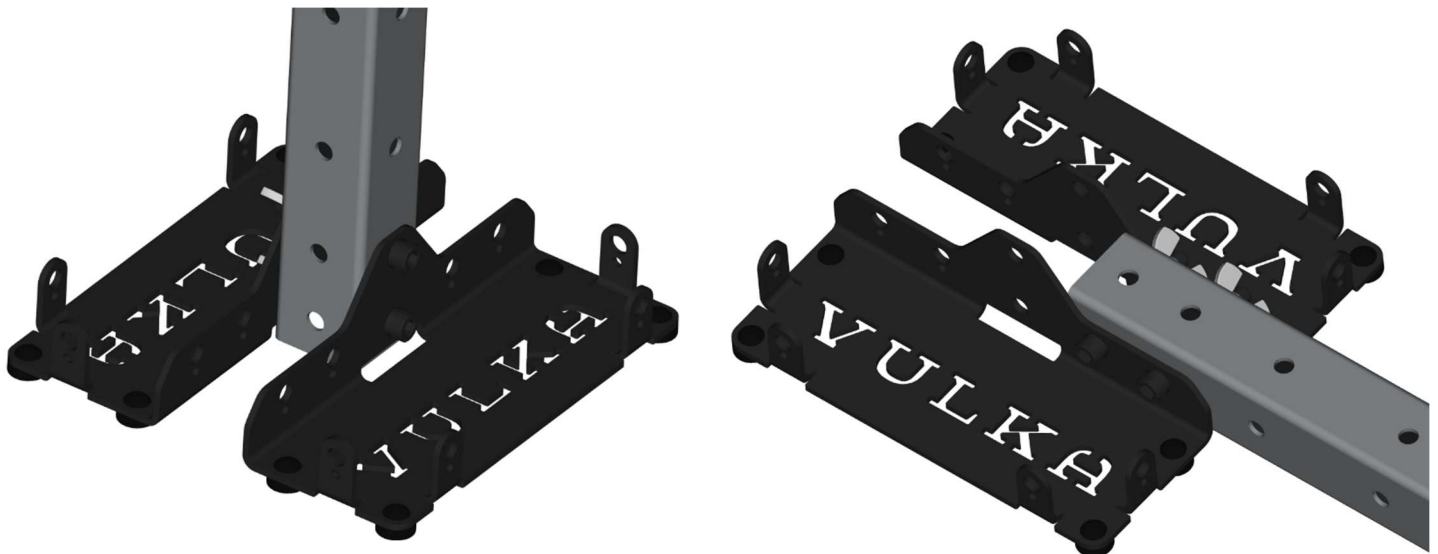

The tabs around the edge of the base allow for connecting tube or lumber to extend the effectiveness of the base or to tie more than one base together:

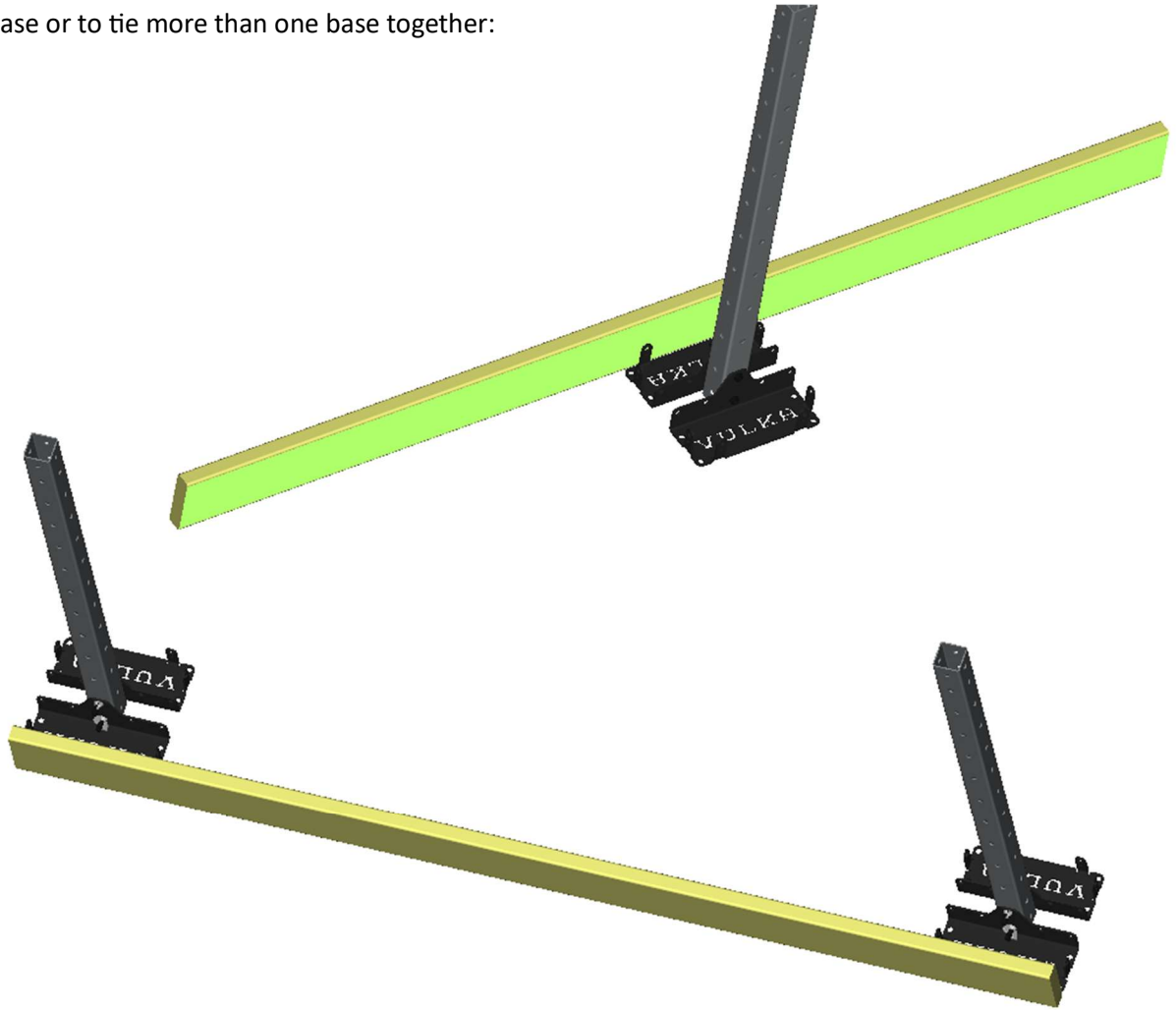

The space between the two bases allows for the connection of tube segments between them:

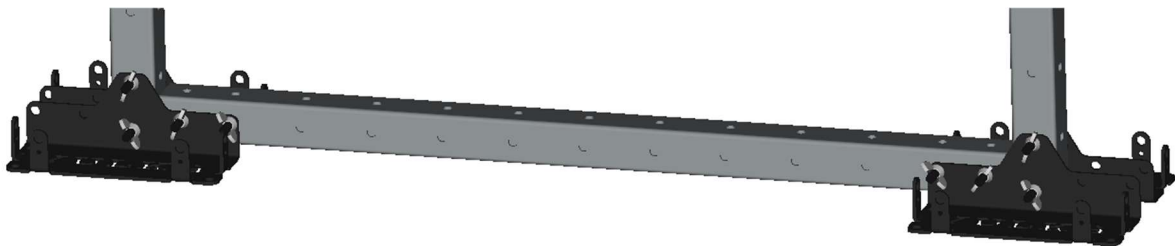

**Elbow:**

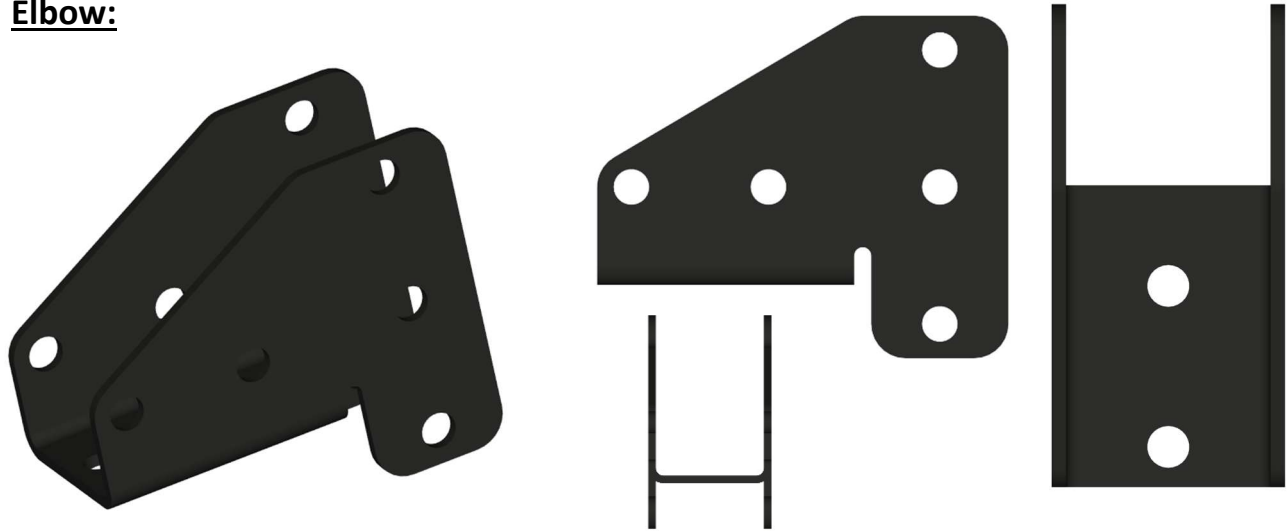

The elbows are used to connect tube segments together at 90 degree angles. The 3 vertical holes allow for connection between the 4" spaced holes on the tube or the end holes on the tube. The 2 holes on the underside of the elbow allow for tube attachment in the vertical and horizontal planes, reducing system play. Tube attachment generally looks like the following:

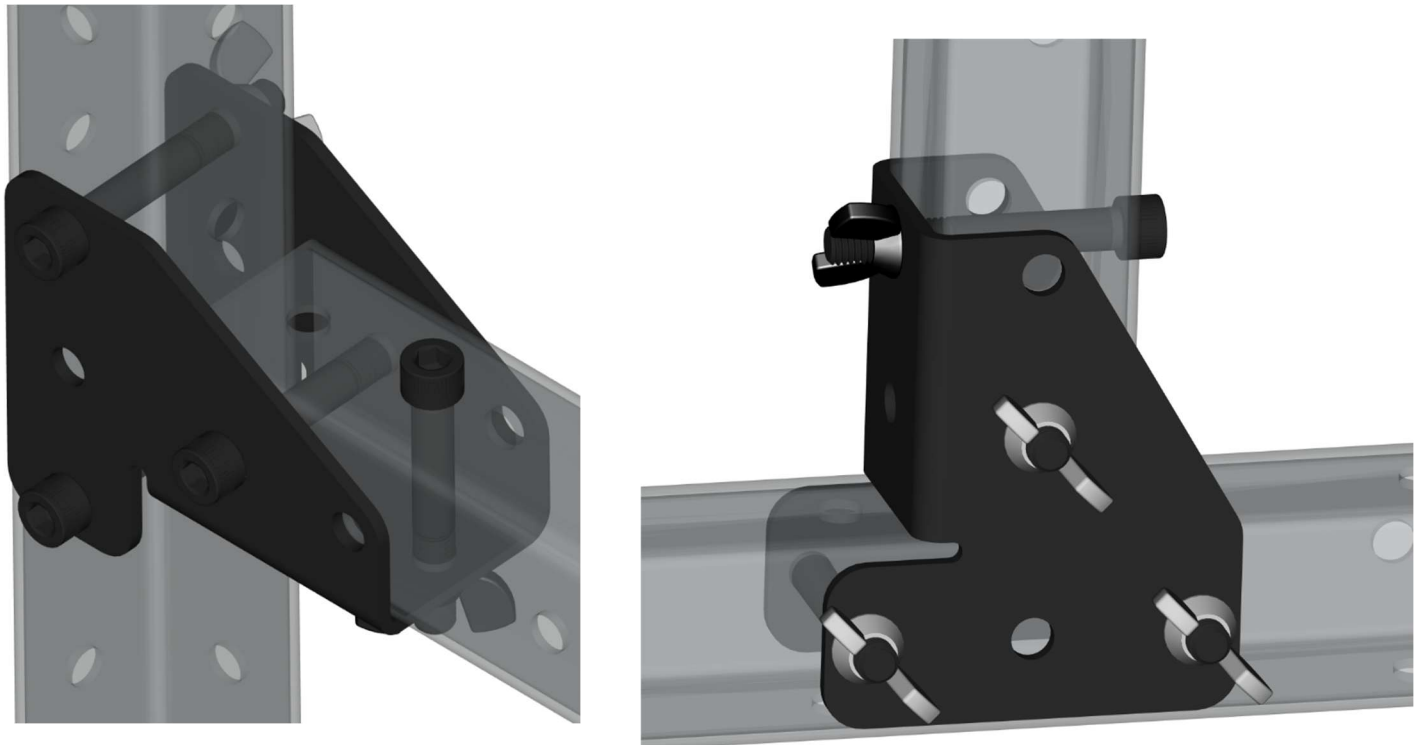

**Connector:**

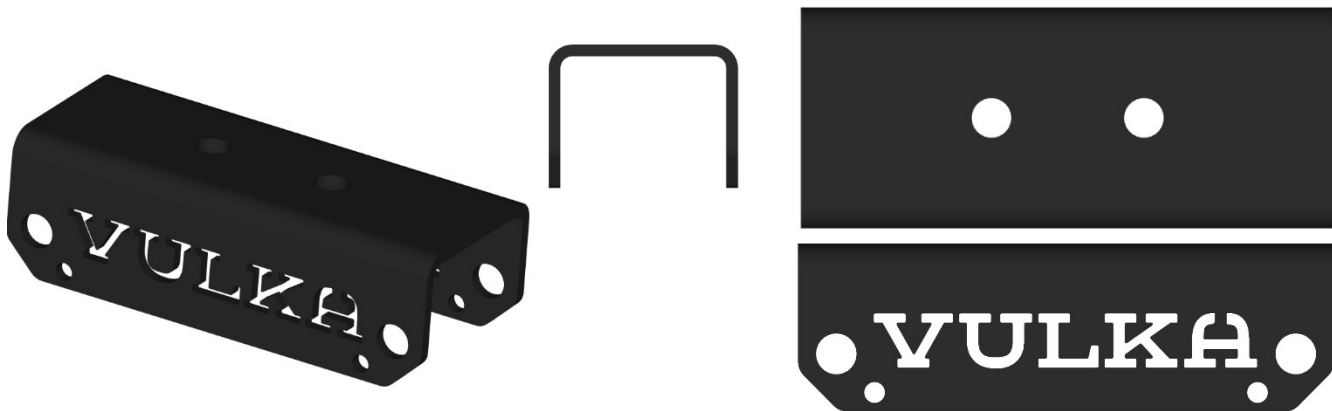

The connectors are used to securely connect 2 sections of tube together:

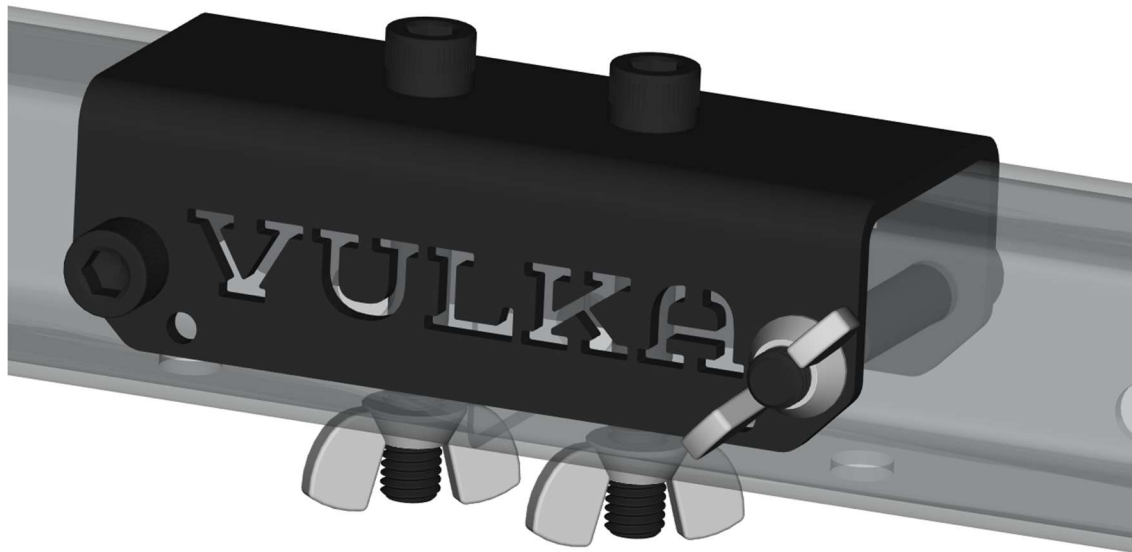

**WARNING:** Do not exceed 3 tube lengths (approx. 12') connected in series. The system weight limit is not rated beyond 12' of tube.

**Bracket:**

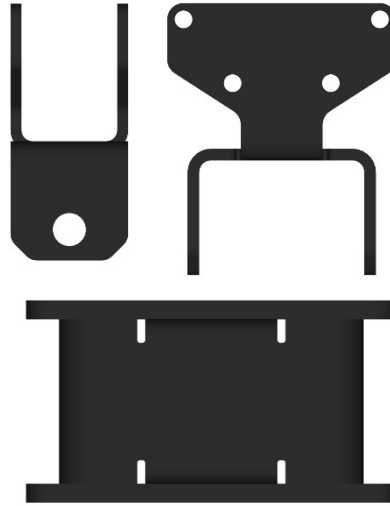
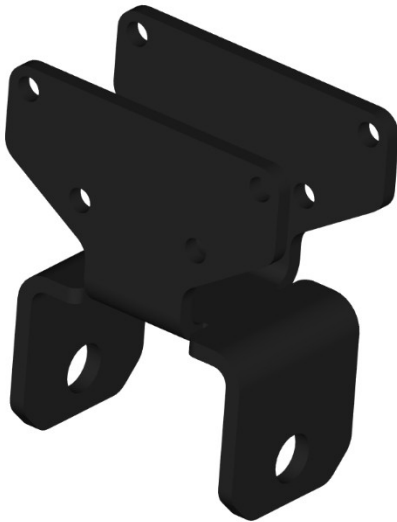

Brackets are the primary means of connecting lumber to the system. The brackets can fit any 1.5 inch width lumber (nominal sizes: 2x4, 2x6, 2x8...). The brackets are secured to the tube with a single bolt, and the lumber simply sits in the channel and is secured using screws:

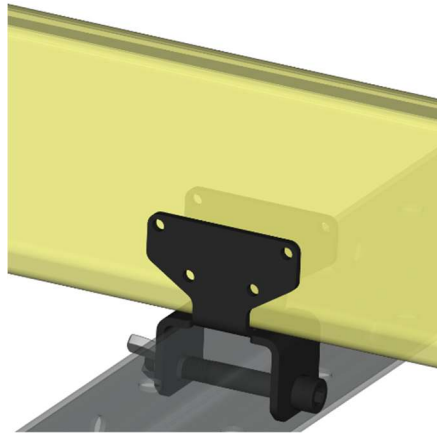
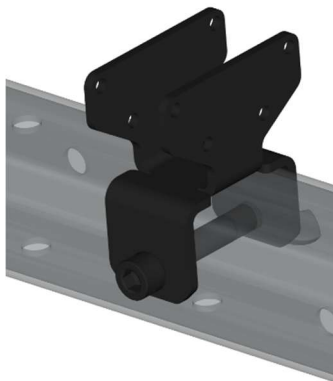

In a pitched roof configuration, the bracket also serves as a hinge point:

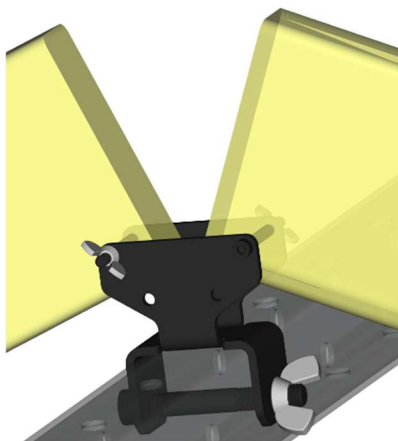
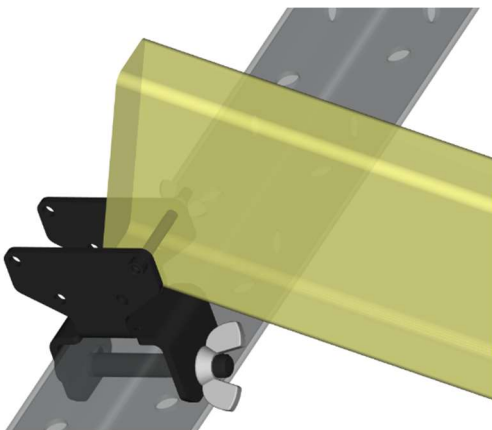

## Bolts:



The VTS comes with 2 sizes of bolts with accompanying wing nuts. The bolts are black steel and the wingnuts are zinc plated. This should make it easy to look at a bolt and tell if it has a nut on it. This also helps the nuts stand out from the parts that are powder coated black.

### ½" Bolts

These 3.5" long bolts are used to attach the tube to the various parts and brackets. Most of the time, two bolts are required for each connection to ensure the strength and stability of the system. Brackets only require a single bolt.

### ¼" Bolts

Requiring pre-drilled 3/8" holes, these bolts are used for hinging the lumber in the bracket to place the lumber at an angle, such as with a peaked roof configuration. These can also be used to attach lumber to bases so that screws do not have to be utilized.

## **Inserting and Securing Bolts**

When securing bolts with wing nuts, bolts should only be hand tight. Using a 3/8" hex key will help snug the bolts tight and reduce play in the system. **Do not overtighten the bolts or use any powered tools on the bolts.** Overtightening the bolts could lead to permanent bending of the brackets and difficulty removing the bolts. Though uncommon, a bolt may require light tapping with a rubber mallet when inserting or removing due to slight hole size variance and/or powder coating thickness – if this is needed, be sure to use as little force as necessary to get the bolt through.



## VTS Part Inventory

Each VTS unit comes with the following compliment of parts:

| Part                               | Qty. |
|------------------------------------|------|
| Tube                               | 12   |
| Bases                              | 8    |
| Elbows                             | 8    |
| Connectors                         | 6    |
| Brackets                           | 18   |
| Bolts (1/2"x3.5")<br>1/2" Wingnuts | 60   |
| Bolts (1/4"x2.5")<br>1/4" Wingnuts | 18   |



## **Question? Concerns? Improvements?**

Please be sure to reach out to us at [support@vulkafire.com](mailto:support@vulkafire.com) !

Specific configurations are available in their own Field Guides. Please be sure to check [vulkafire.com](http://vulkafire.com).

Add-ons for the VTS are also available at [vulkafire.com](http://vulkafire.com)!

# **END OF GUIDE**